



User manual

Telescopic actuator LATT + electronic control module MINI-SA



Edition: 2020

Revision: A

RADIA SRL – ITALY



Preface, disclaimer, copyright, trademarks and patents

This documentation is intended exclusively for the use of specialists in the field of automation and control of electric motors. During the installation it is essential to follow the documentation and notes introduced to complete the description. It is the responsibility of the technical staff to use this documentation at the time of each installation and commissioning. The responsible staff shall ensure that the application or use of the described products meets all safety requirements, including all relevant laws, regulations, guidelines and standards.

The documentation has been carefully prepared. The products described are, however, constantly being developed, improved and updated. The company reserves the right to make changes to the contents described for technical or commercial reasons, as well as for adaptation to the legal requirements in force in the various countries, without therefore being bound by obligations to update this publication immediately. Therefore, the data contained in this publication may not be updated.

No complaint can be made for the modification of products that have already been provided, based on the data, diagrams and descriptions contained in this documentation.

Photographs, texts and drawings relevant to the work contained in this publication are protected by copyright. Other designations used in this publication may be trademarks, models or patents whose use by third parties for their own purposes may infringe the rights of the owners.

RADIA SRL

Via Marconi, 65/A – 10040 PIOBESI TORINESE (TURIN) - ITALY

VAT – TVA number : IT06198850015

☎ Phone: +39 0119936019

✉ e-mail: inforadia@radiamotion.com

🌐 Web site: www.radiamotion.com

Indice generale

1 Description.....	5
2 Applications.....	5
2.1 Openframe version – IP00 – standard connections.....	6
2.2 Version Enclosed – IP30 – Standard connection.....	7
2.3 Version Enclosed – IP30 – Cable gland M12 connection.....	8
3 General characteristics.....	9
3.1 Table of main technical characteristics.....	9
3.2 Mechanical dimensions version Openframe.....	10
3.3 Mechanical dimensions standard version.....	11
3.4 Mechanical dimensions cable gland M12 version.....	12
3.5 Connector X1 version Openframe and Standard.....	13
3.5.1 Electrical characteristics of the connector.....	13
3.5.2 Designation of pins.....	13
3.5.3 Connecting connector for wiring.....	14
4 Standard cable L = 400mm.....	14
4.1 Terminal designation and wire colour.....	14
5 Shielded cable L = 500mm.....	16
5.1 Terminal designation and wire colour at JST PHR-6 connector 2mm pitch:.....	17
5.2 DC Drive Controller Side Wiring Connector.....	17
5.3 Terminal designation and wire color at JST XHP-6 connector 2.5mm pitch.....	18
5.4 External side wiring connection connector.....	18
6 Inputs.....	19
6.1 Description of the inputs.....	19
6.2 Entry circuit.....	19
7 Outputs.....	20
7.1 Description of the outputs.....	20
7.2 OC-OUTPUT Setup.....	20
8 Electrical connection Type 1.....	21
9 Electrical connection Type 2.....	22
10 Electrical connection Type 3.....	22
11 Electrical connection Type 4.....	23
12 Electrical connection type 5.....	23
13 Electrical connection Type 6.....	24
14 Electrical connection Type 7.....	24
15 Power supply.....	25
16 EMC and ground connection.....	26
17 Operation.....	26
17.1 Switching on the linear actuator LATT.....	27
17.2 First power on the Telescopic actuator.....	27
17.3 Sleep Mode e Standby Motor.....	28
17.4 Security and Alarms.....	28
18 Change of motor speed.....	30
19 Virtual limit switch.....	30
20 Procedure for acquisition of virtual limit switches.....	32
20.1 Acquisition of virtual limit switches via DAC console.....	33
20.1.1 Power connector 12/24 VDC, 5A.....	34
20.1.2 Identification plate on the back of Console 12 and 24 VDC.....	34
20.1.3 Connector for LATT connection cable.....	35
20.1.4 Console operating procedure with LATT and M12 cable gland.....	35
20.2 Warnings on the positioning of limit switches.....	35
20.2.1 Mechanical stop.....	36
20.2.2 Safety Zone.....	36
20.3 Arbitrary positioning of virtual limit switches.....	36

20.3.1 Full-stroke positioning.....	36
20.3.2 Positioning in the middle.....	37
20.3.3 Positioning close to the reverse end or CCW.....	37
20.3.4 Positioning close to the forward end or CW.....	37
21 Speed and Position Control.....	38
22 Acceleration and Deceleration.....	39
23 Automatic deceleration before the stop.....	40
24 Dynamic Acceleration and Deceleration.....	40
25 Switching from START to STOP to START.....	42
26 Last position reached.....	43
26.1 Endurance.....	43
26.2 Irreversibility of the mechanism.....	43



1 Description

This model of Telescopic Linear Actuator LATT is equipped with control electronics called MINI-SA. To know all the details of the DC Drive Controller, please refer to its user manual. The motors inserted in the actuator can be of 0,5A, 1A, 2A, 4A, to 12VDC or 24VDC. The telescopic actuator is available in the main transmission ratios of 1:12, 1:27, 1:48 and the electrical connection to the actuator can be in the standard version with 2 mm 6-way pitch JST male connector, or in the version with M12 cable gland and shielded cable with extension of connections to the outside up to 500 mm and terminated with a JST XHP connector with 2.5 mm 6-way pitch.

2 Applications

This system is suitable for a wide range of machines, equipment and tools: as medical equipment, small automatic machines, automatisms in general, automatic controls, packaging industry, home automation, agricultural automation, milling industry automation, material handling, transport vehicles, sweepers, etc. Particularly suitable for applications that require minimum space, minimum vibration, low noise, high speed and high precision, at low cost. This system is suitable for the control of linear actuators and telescopic actuators, adapting to the main configurations available, from a few centimeters up to 1000 [mm] of release length.



2.1 Openframe version – IP00 – standard connections

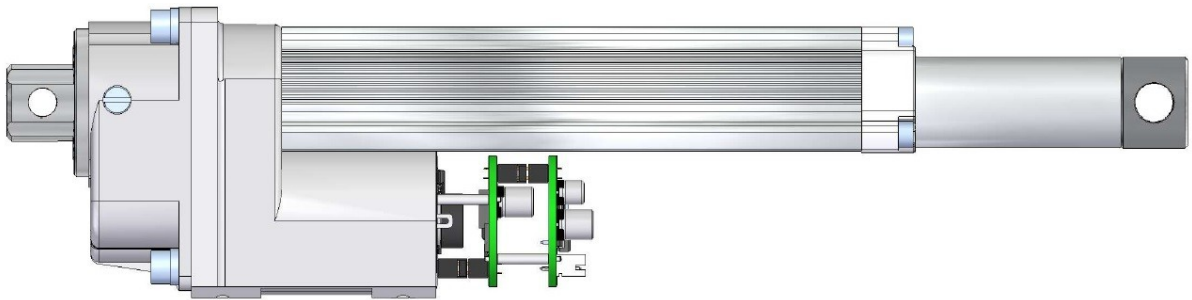

Note: the Openframe model should be used within an environment protected from dust, chips, splashes of water or liquids of any kind. The male connector X1 JST PHR-6 2 mm pitch 6-way can be connected with wires or sheathed, unprotected or shielded.



2.2 Version Enclosed – IP30 – Standard connection

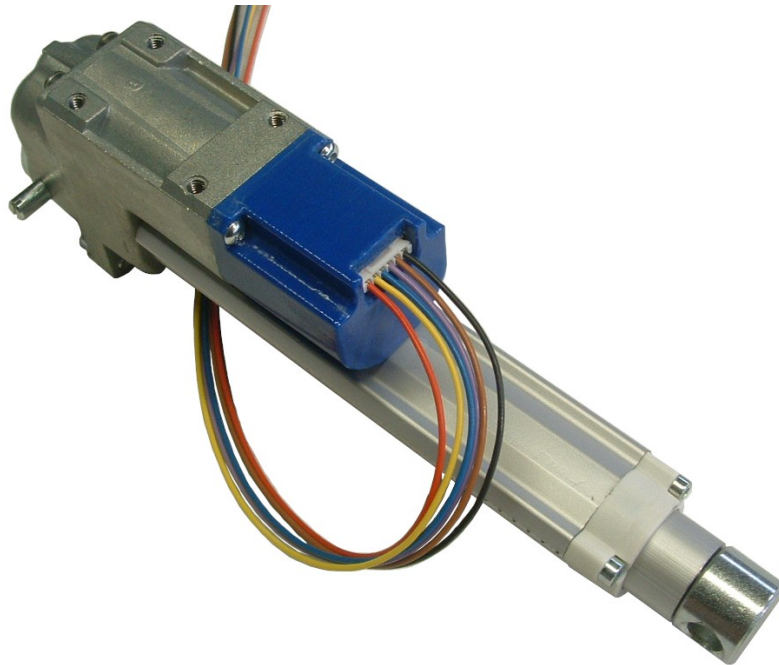
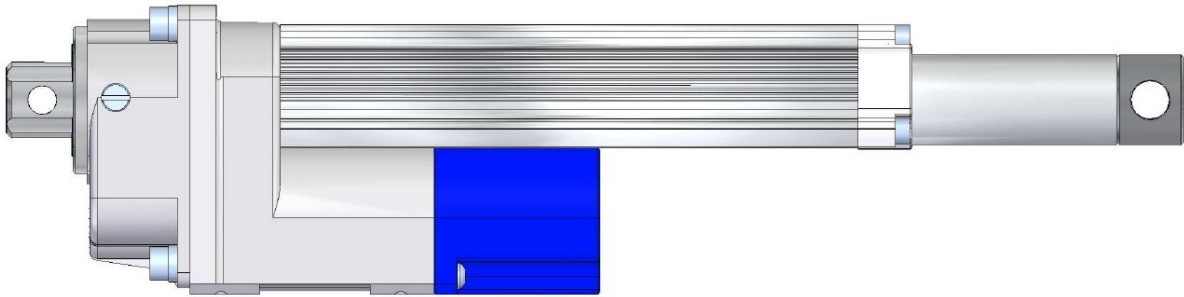

Note: The standard model makes use of connections to the male X1 JST PHR-6 2 mm pitch 6-way connector with flying wires or sheathed, unshielded or shielded.



2.3 Version Enclosed – IP30 – Cable gland M12 connection

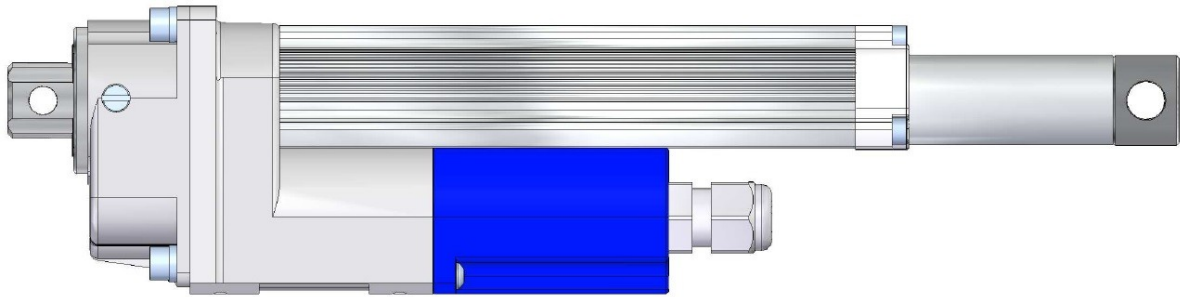

Note: The M12 cable gland model has a shielded 6-wire cable of 500 mm length, terminating in a 2.5 mm 6-way JST PHR-6 female connector.



3 General characteristics

In this model, called LATT + Mini-SA, the RS485 communication is not active and for this reason it has an autonomous pre-programmed operation. (see DC Motor controller MINI-SA User Manual).

3.1 Table of main technical characteristics

<i>Denomination</i>	<i>Minimum</i>	<i>Typical</i>	<i>Maximum</i>	<i>Unit of measure</i>
Power supply	10	24	28	[VDC]
Motor current	0.5	-	4	[A]
Motor power	5	-	100	[W]
Current in Standby	17 @ 28V	-	38 @ 10V	[mA]
Power consumption in Standby	0.3	-	0.5	[W]
Duty Type (not ventilated)	S3: 25% (15 Sec. / 60 Sec.)			
Output current Open Collector NPN	-	-	500	[mA]
Working temperature	-10	25	40	[°C]
Storage temperature	-20	-	65	[°C]
Relative humidity of operation	-	-	80	[%]
Degree of protection (Openframe)	IP00			
Degree of protection (Enclosed)	IP30			
Weight	Depends on actuator stroke Ex: stroke 100 mm 600 g add 100 g per 100 mm stroke			



3.2 Mechanical dimensions version Openframe

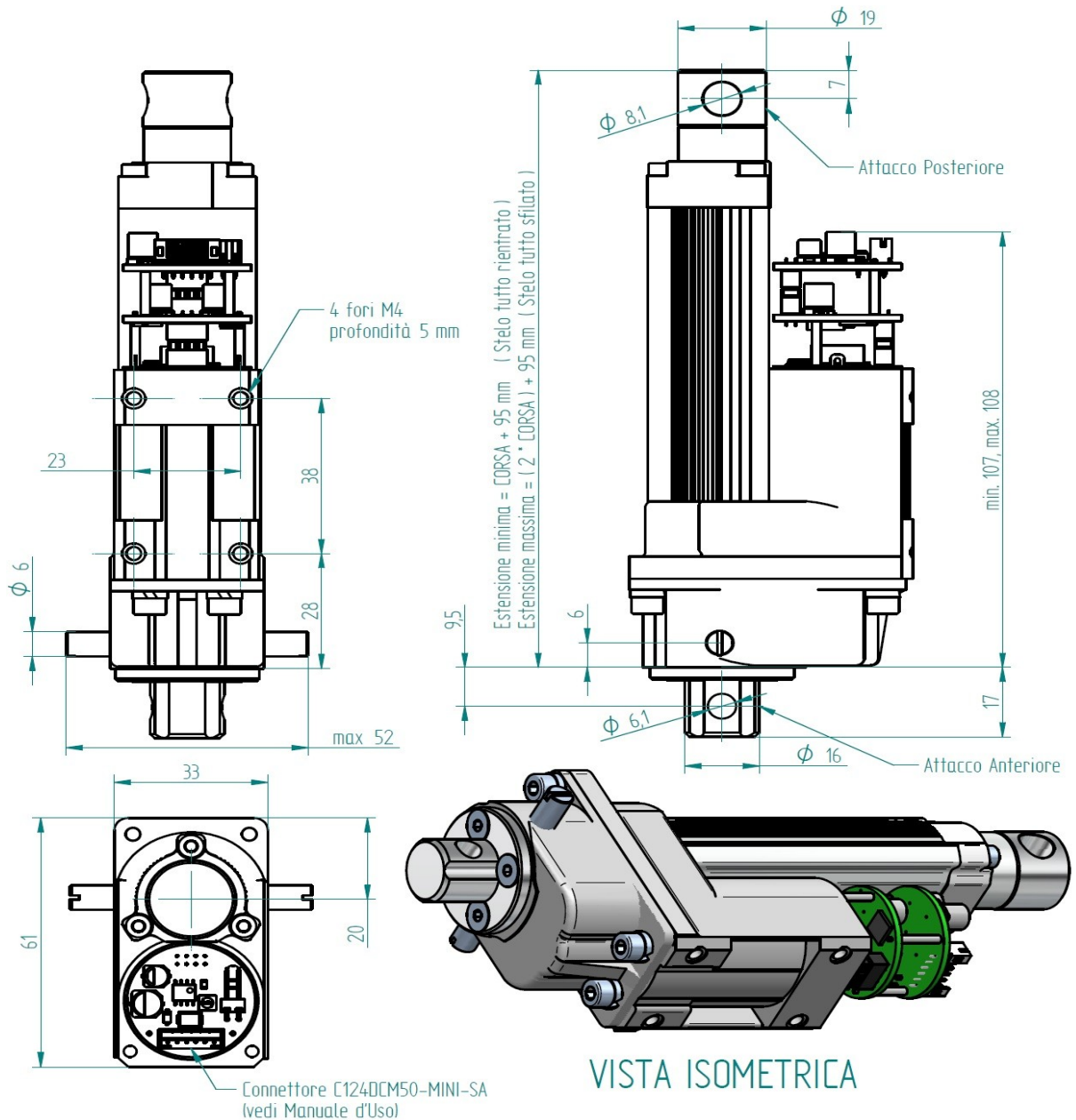



3.3 Mechanical dimensions standard version

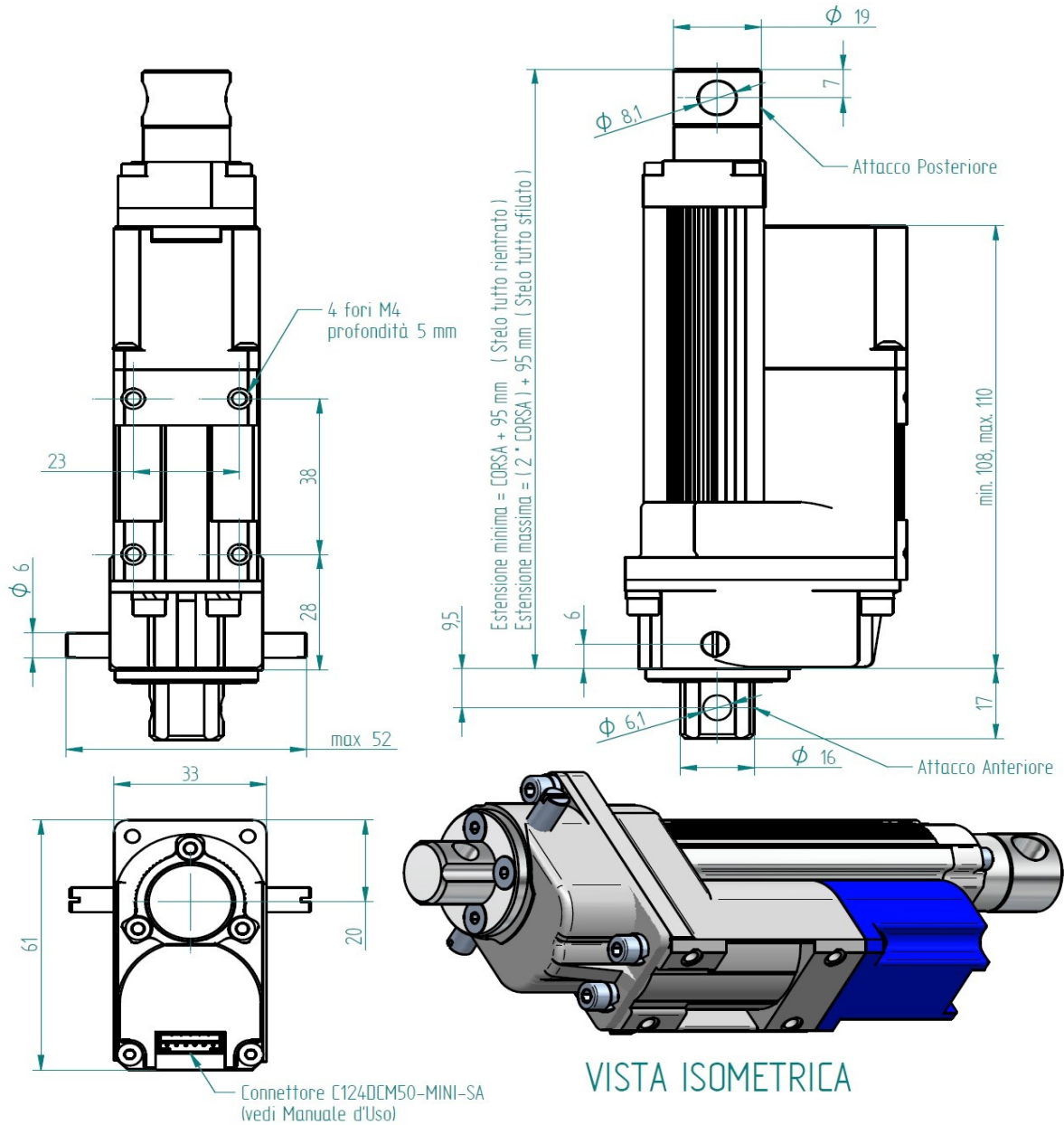



3.4 Mechanical dimensions cable gland M12 version

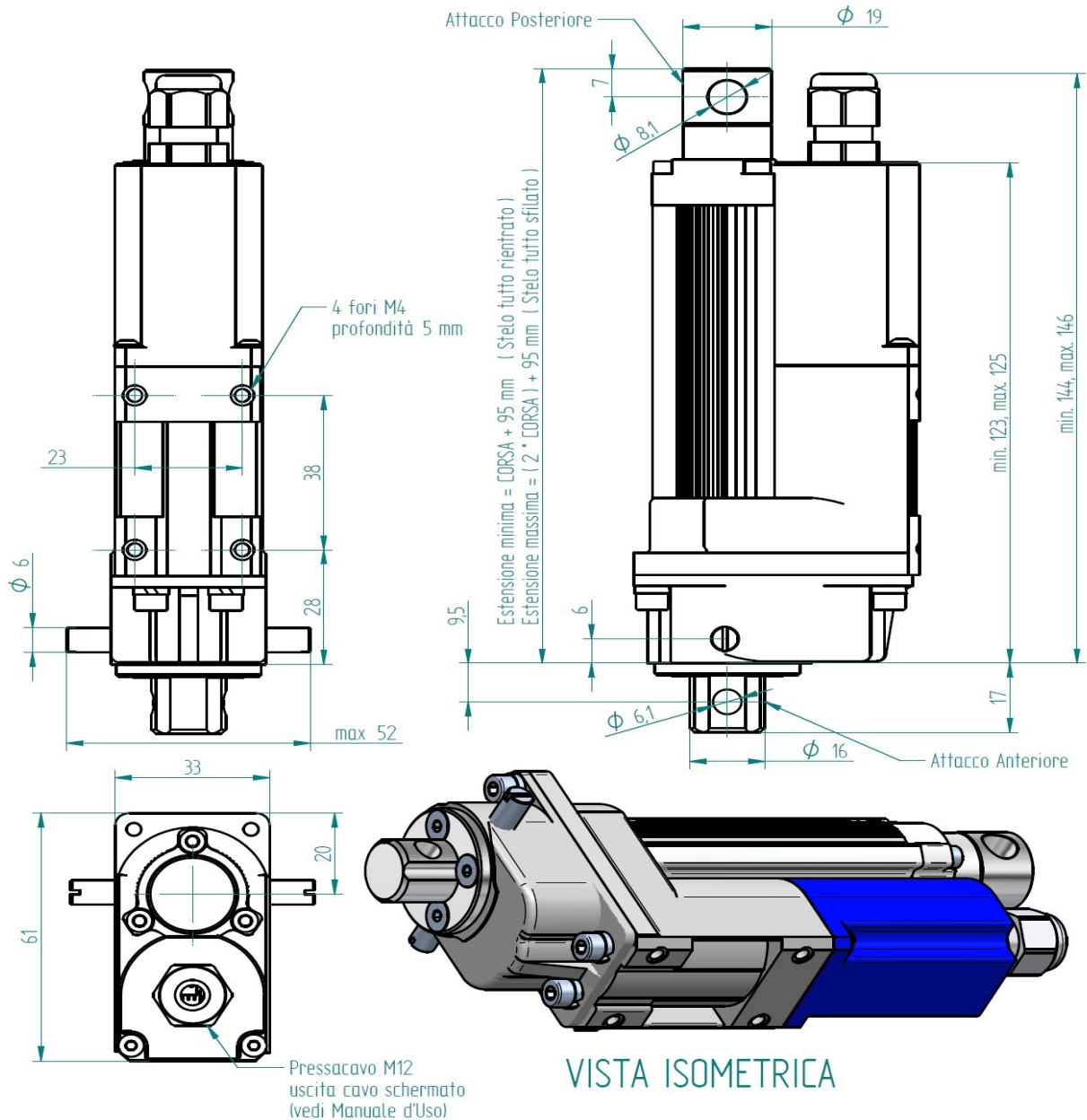



3.5 Connector X1 version Openframe and Standard

The X1 connector is available in the Openframe and Standard versions, it is 1 row to 6 ways and they head, the power supply, all the control inputs and the open collector output.

The connector is male type JST pitch 2 mm Manufacturer Code: B6B-PH-K-S(LF)(SN).

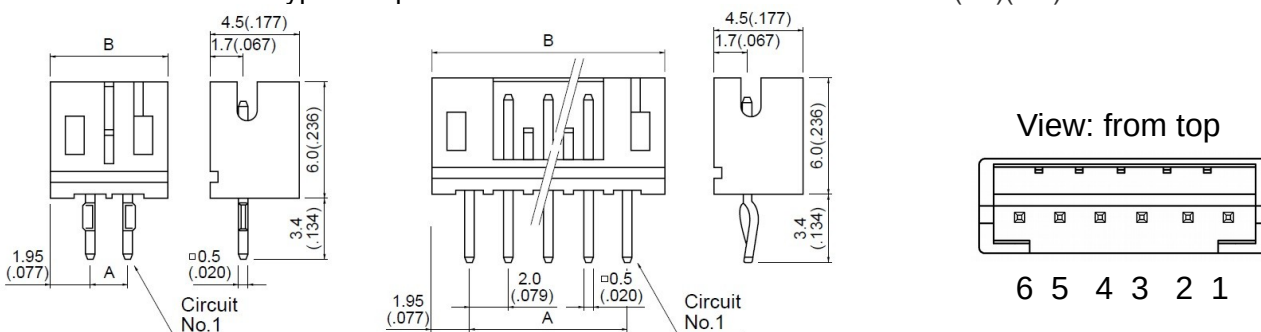

Alternative WURTH ELEKTRONIK – WR-WTB, manufacturer code: 620 006 116 22.

3.5.1 Electrical characteristics of the connector

- Rated current: 2A
- Rated voltage: 125VAC
- Contact resistance: 20mOHM max

3.5.2 Designation of pins

Terminal number	Designation	Function
1	+Vcc	Positive power supply
2	START/STOP	Control input
3	FWD/REV	Control input
4	SPEED	Control input
5	OC-OUTPUT	Exit
6	GND	Power supply reference



3.5.3 Connecting connector for wiring

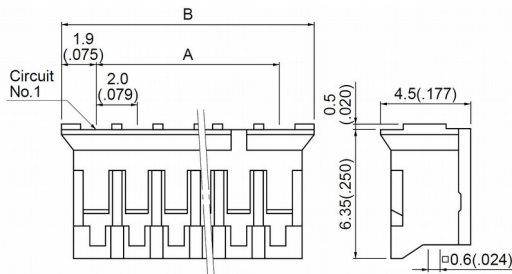

Connector, JST, manufacturer code: PHR-6
Terminal, JST, manufacturer code: BPH-002T-P0.5S

Connector, WE, manufacturer code: 620 006 113 322
Terminal, WE, manufacturer code: 620 001 137 2

4 Standard cable L = 400mm

The standard connection cable of the telescopic linear actuator consists of 6 wires of different color and a female connector JST PHR-6 2 mm pitch. The useful length of the wires is 400 mm. This connection cable is used both in the Openframe version and in the Enclosed Standard version.

4.1 Terminal designation and wire colour

Terminal number	Designation	Colour
1	+Vcc	Red
2	START/STOP	Yellow
3	FWD/REV	Blue
4	SPEED	Violet
5	OC-OUTPUT	Maroon
6	GND	Black



Note: The standard cable consists of 0.22 mm² section wires and the free terminations of the wires are peeled for 5 mm to facilitate connection.



5 Shielded cable L = 500mm

The connection cable of the telescopic linear actuator in the screened version is composed of 6 wires of different color, to which the female connector JST XHP 2.5 mm 6-way pitch mounted at one end, while on the other there is a female connector JST PHR-6 2 mm pitch. The useful length of the cable is 500 mm. This connection cable is used both in the M12 cable gland version and as an adapter for the connection of the DAC console for the acquisition of virtual limit switches in the enclosed standard version.



Note: the cable is shielded and consists of 6 wires of section 0.25 mm².



5.1 Terminal designation and wire colour at JST PHR-6 connector 2mm pitch:

Terminal number	Designation	Colour
1	+Vcc	Maroon
2	START/STOP	Green
3	FWD/REV	Grey
4	SPEED	Pink
5	OC-OUTPUT	Yellow
6	GND	White

5.2 DC Drive Controller Side Wiring Connector

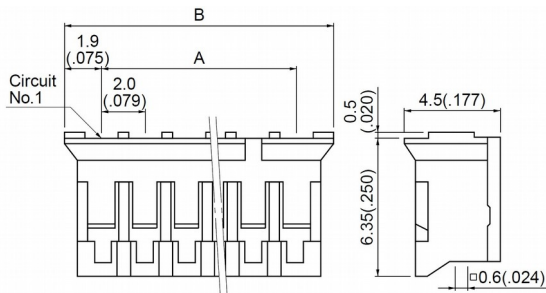

Connector, JST, manufacturer code: PHR-6
Terminal, JST, manufacturer code: BPH-002T-P0.5S

Connector, WE, manufacturer code: 620 006 113 322
Terminal, WE, manufacturer: 620 001 137 22



5.3 Terminal designation and wire color at JST XHP-6 connector 2.5mm pitch

Terminal number	Designation	Colour
1	+Vcc	Maroon
2	START/STOP	Green
3	FWD/REV	Grey
4	SPEED	Pink
5	OC-OUTPUT	Yellow
6	GND	White

5.4 External side wiring connection connector

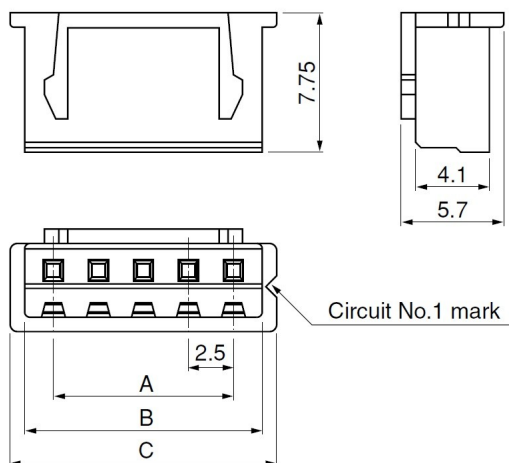

Connector, JST, manufacturer code: XHP-6
Terminal, JST, manufacturer code: SXH-001T-P0.6



6 Inputs

The Drive Controller has 3 control inputs:

Pin 2: START/STOP

Pin 3: FWD/REV

Pin 4: Speed

6.1 Description of the inputs

START/STOP: this input has the function to start the Motor Control when it is in START condition. The START condition is activated when the input is closed to GND and there are no alarms. If the input remains free, not closed towards GND, the STOP condition is activated.

If the input is in the START condition on ignition, the "incorrect Start" alarm is generated. Switch the input to STOP to clear the alarm.

FWD/REV: this input selects the forward/backward direction.

Speed: this input has the function of selecting the speed of the DC Motor in steps of 10% from 0 to 100% and return. In the acquisition phase of the limit switches the initial speed is always at the value of 0%.

6.2 Entry circuit

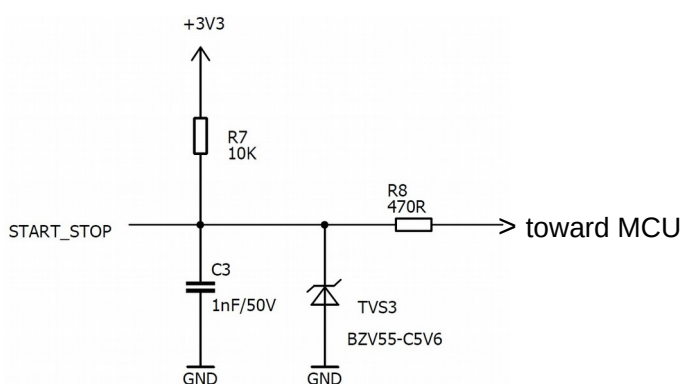

Input circuit START/STOP

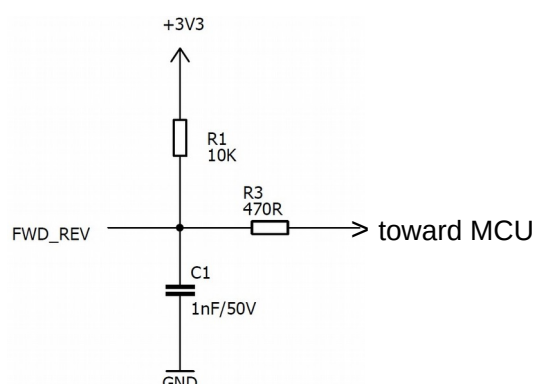

Input circuit FWD/REV e Speed

RADIA SRL – VIA MARCONI, 65/A – 10040 PIOBESI TORINESE (TORINO) ITALY			Rev.
Tel. : +39 011 9936019	e-mail: inforadia@radiamotion.com	Web site: www.radiamotion.com	A



7 Outputs

II DC Drive Controller has 1 output

Pin 5: OC-OUTPUT

7.1 Description of the outputs

The DC Drive Controller has a single output called OC-OUTPUT, dedicated to the control of a load with maximum absorption of 500 mA. The output driver is presented in the typical configuration called NPN Open-Collector and uses as reference potential the GND. For this output there are 10 operating modes.

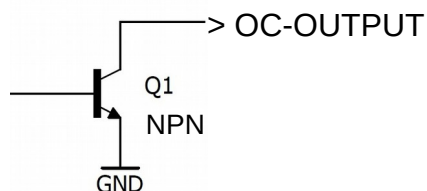

7.2 OC-OUTPUT Setup

The operating mode of the output is chosen on request from among 10 available variants, the number associated with the configuration parameter corresponds to the number of the list:

- 0) OC output does nothing, no activity
- 1) OC output indicates the alarm number (intermittence and pause)
- 2) OC output is activated immediately after ignition if no alarm is present
- 3) the OC output is activated only on the virtual limit switch forward (FWD or CW)
- 4) the OC output is activated only on the virtual reverse limit switch (REV or CCW)
- 5) OC output is activated on both virtual limit switches
- 6) the OC output is activated at half distance with a 1 mm window
- 7) option 3 + option 6
- 8) option 4 + option 6
- 9) option 5 + option 6

The OC-OUTPUT output in the 0 configuration does nothing, meaning the output transistor never switches to the DC Drive Controller in any condition. Depending on the demand and therefore the use, it is possible to set during manufacturing one of the operating options of the OC-OUTPUT output. If not specified, the default setting during manufacturing is number 1.



Note 1: In all 1-9 configurations, excluding configuration number 0, the OC output is also used to display the operating status during the limit switch capture procedure.

Note 2: In options 3-4-5, the OC output assumes the activity state only if the position is stable for at least **0,5 seconds**. (anti-bounce function)

Note 3: In option 6, the OC output has a timed monostable operation, meaning it maintains the activity state for **0.5 seconds** even after leaving position. If the position control is stopped around the mid-point of the total path, with a tolerance of $\pm 1 \text{ mm}$, the OC output also keeps its state of activity stable.

8 Electrical connection Type 1

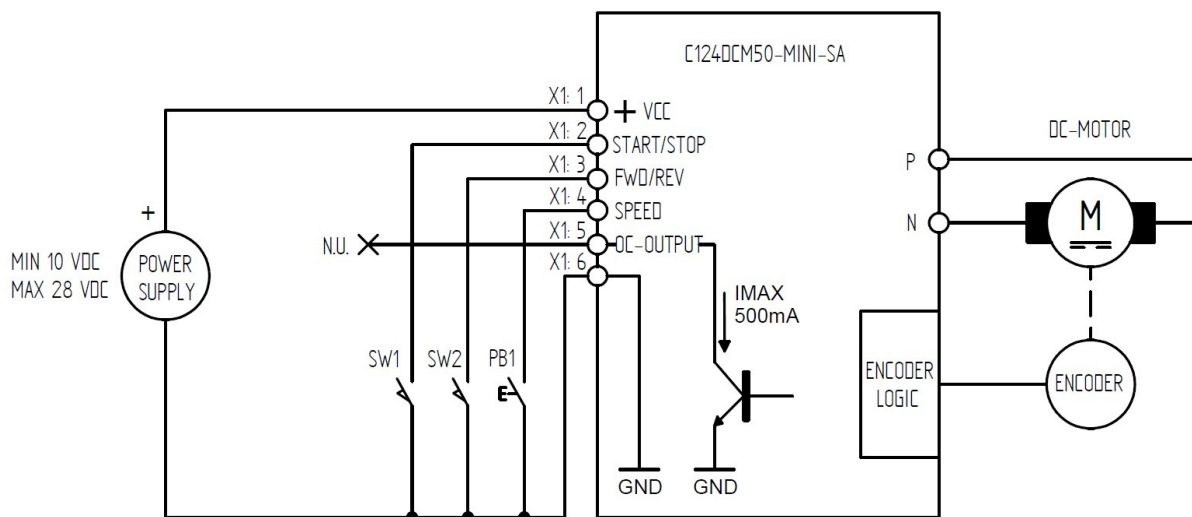

- START/STOP and FWD/REV control inputs made by electromechanical switches, SW1 and SW2.
- Speed control input made by means of an electromechanical PB1 button.
- Unused and unrelated OC-OUTPUT output.



9 Electrical connection Type 2

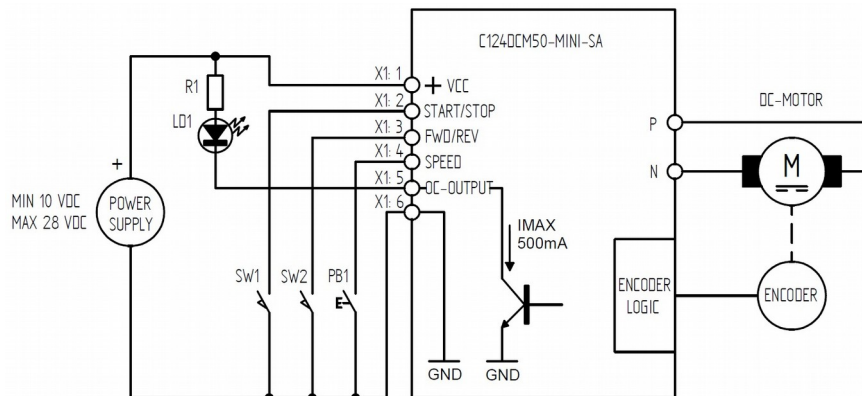

- START/STOP and FWD/REV control inputs made by electromechanical switches, SW1 and SW2.
- Speed control input made by means of an electromechanical PB1 button.
- Used OC-OUTPUT output and connected to a signaling LED diode.

10 Electrical connection Type 3

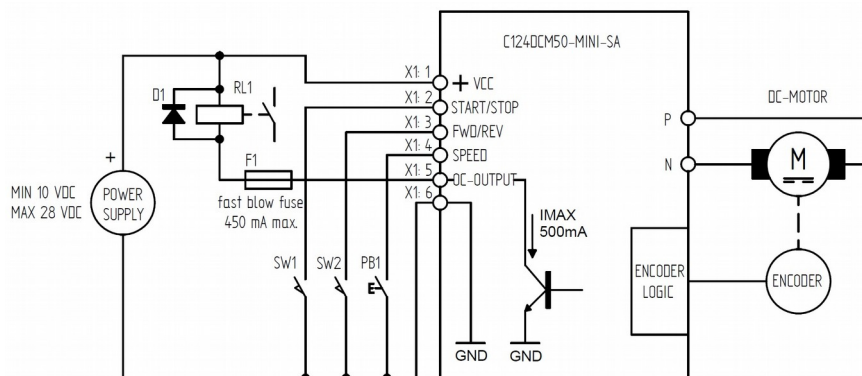

- START/STOP and FWD/REV control inputs made by electromechanical switches, SW1 and SW2.
- Speed control input made by means of an electromechanical PB1 button.
- OC-OUTPUT output used and connected to the coil of a Relay by means of F1 Quick Fuse.

11 Electrical connection Type 4

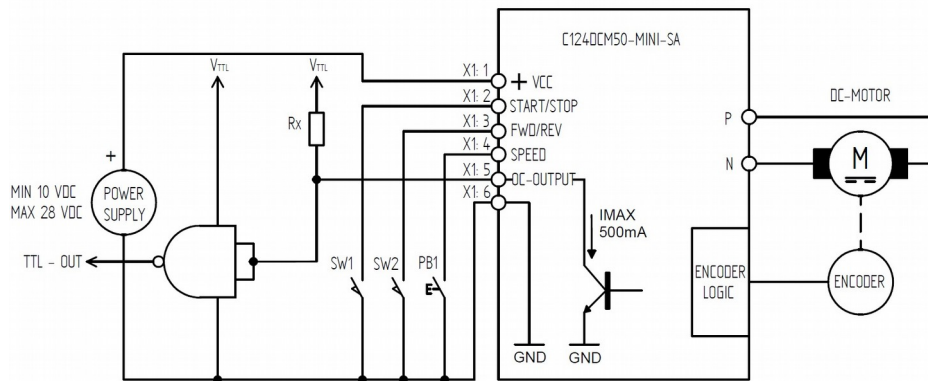

- START/STOP and FWD/REV control inputs made by electromechanical switches, SW1 and SW2.
- Speed control input made by means of an electromechanical PB1 button.
- OC-OUTPUT output used and connected to a TTL logic circuit.

12 Electrical connection type 5

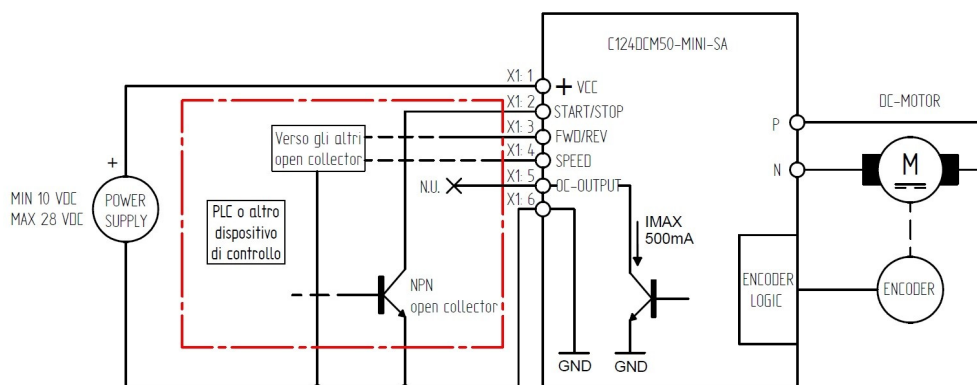

- START/STOP, FWD/REV and Speed control inputs are made by connecting to the NPN - Open collector outputs of a PLC control.
- Unused and unrelated OC-OUTPUT output.

13 Electrical connection Type 6

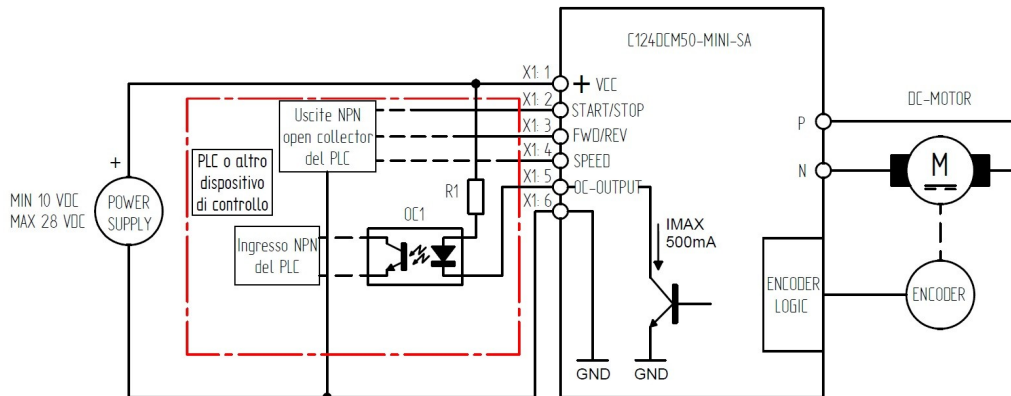

- START/STOP, FWD/REV and Speed control inputs are made by connecting to the NPN - Open collector outputs of a PLC control.
- OC-OUTPUT output used and connected to a photo-coupled NPN input.

14 Electrical connection Type 7

This connection is particularly suitable for controlling the telescopic linear actuator by means of three buttons and man present. The connection provides for the control of the actuator in reverse and forward gear, with only the pressure of one of the buttons PB1 and PB2, respectively. The PB3 button adjusts the scrolling speed in both directions.

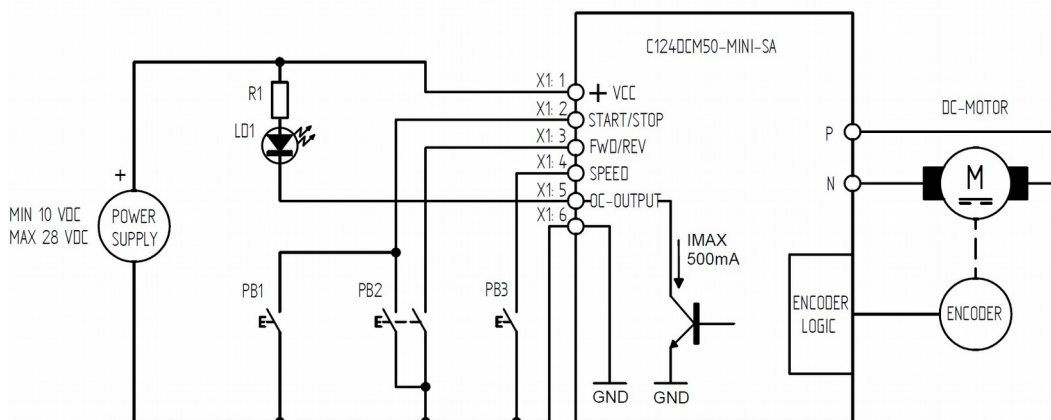



- **PB1** is an electromechanical single contact button N.O. (normally open) connected to the START input. Reverse button (**REVERSE**)
- **PB2** is a double-contact N.O. (normally open) electromechanical button connected, one at the START input and the other at the FWD/REV input, activated simultaneously. This is the forward button (**FORWARD**)
- **PB3** is an electromechanical single contact button N.O. (normally open) connected to the Speed input.
- **OC-OUTPUT** used and connected to a signalling LED diode. To connect the output in a configuration other than this, refer to the above connection diagrams.
- **Note 1:** The PB2 button has the priority of operation. The simultaneous pressing of both PB1 and PB2 gear buttons is equivalent to the pressing of PB2 alone as this is the priority button.
- **Note 2:** The change of speed by pressing PB3 only occurs if one of the two running buttons PB1 or PB2 is also pressed.
- **Note 3:** The telescopic linear actuator movement is in START-STOP-START mode, see the relevant chapter.
- **Practical example:** the codes of the main components for the realization are listed below.

3 x Button Black cod: **ZB4 BA2** (Schneider Electric)

3 x Push button support complete with a contact N.O. code: **ZB4 BZ101** (Schneider Electric)

1 x Contact N.O. code: **ZBE 101** (Schneider Electric)

15 Power supply

The power supply to the DC Drive Controller must be direct current and must be supplied respecting the polarity as described in the previous chapters. During manufacture, within the memory of each Controller are inserted some parameters that establish the rated supply voltage that is usually of two values: 12 VDC and 24 VDC. Depending on this value, choose a power source 12V or 24V stabilized with a variability of 10% and must be guaranteed a maximum current of 5A to meet the demands of the torque points avoiding voltage drops that would be interpreted by the DC Drive Controller as a condition alarm.

Rated power supply	Minimum value	Maximum value	Maximum current
12 VDC \pm 10%	10,8 VDC	13,2 VDC	5A
24 VDC \pm 10%	21,6 VDC	26,4 VDC	5A



16 EMC and ground connection

In order to suppress electromagnetic emissions, all DC micromotors are internally equipped with ceramic filter capacitors.

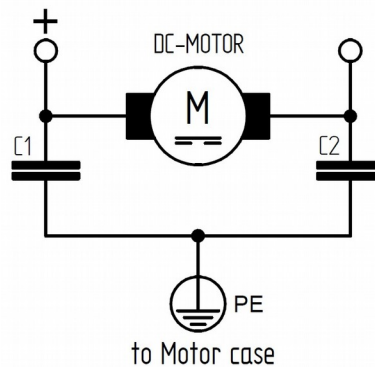

Both C1 and C2 capacitors are connected between the end of the brush and the motor body as shown in the figure. The body of the DC Motor is considered the potential of the ground and for this must necessarily be connected to the ground protection of the electrical system to which the Motor is connected. The body of the motor, in most cases, is fixed and screwed to the metal body of the reducer. In order to ensure that the electromagnetic disturbances generated by the motor during normal operation occur, it is appropriate to connect the casing or the gearmotor directly to the ground protection (PE) of the electrical system, by means of a yellow/green wire of 0,75 mm².

17 Operation

All signals at the control inputs of the DC Drive Controller must be given according to the following logical state:

START/STOP	0 = START	1 = STOP
FWD/REV	0 = FWD (CW)	1 = REV (CCW)
Speed	0 = Set Speed ON	1 = Set Speed OFF

Note 1: logical state 0 means input connected to GND

Note 2: logical state 1 means free or fluctuating input or high impedance from Opencollector

Note 3: all inputs are equipped with anti-bounce logic



ATTENTION !! : Inputs should only be controlled via Open collector NPN or free electromechanical contacts (free contacts). If you apply to inputs the positive electrical potential at 12V or 24V you destroy the DC Drive Controller irreparably.

The signal received from the OC-OUTPUT output must be managed with respect to the maximum current of 500 mA. The following table describes the operating logic of the OC-OUTPUT output.

NPN device open	High impedance	0 mA towards GND
NPN device closed	Low impedance	500 mA max. towards GND

It is recommended, in applications where the load could be the solenoid of a power relay or the solenoid of a solenoid valve, a **recirculating diode** suitable for the purpose shall be connected in parallel to the solenoid and a **rapid fuse** of not more than **450 mA** shall be inserted in series to the solenoid.

ATTENTION!! : The load connected to the OC-OUTPUT output must not exceed an absorption of 500 mA. If you connect the OC-OUTPUT output directly to +VCC of 12V or 24V you destroy the DC Drive Controller irreparably.

17.1 Switching on the linear actuator LATT

Providing 12V or 24V power to +Vcc and GND, Pin 1 and Pin 6 respectively, after about 200 ms the system is ready and operational to receive and execute the command signals at the preset inputs. As required by the machinery directive and safety regulations, the first command to be given is to provide the START signal. To do this, just close the START/STOP input to GND at Pin 2. Without this signal the Controller remains in the state of inactivity and Standby. After applying the START signal, the Controller is activated by exiting the standby condition and is immediately ready to rotate the DC Motor. At the initial moment of ignition, the Microcontroller performs a series of checks to ensure that there is not at least one fault condition present that generates an alarm. If this happens, the Microcontroller shall carry out all the necessary operations to secure the DC Drive Controller and its user and inform him about the nature of the failure by reporting the alarm number associated with it. (see paragraph: safety and alarms).

17.2 First power on the Telescopic actuator

At the first power on, the system automatically passes into the procedure of acquisition of the limit switches, remaining in a safe condition if the START/STOP input is in the STOP condition. Again, if the first power on, absolutely, occurs with the START/ STOP input switched in the START condition, the system enters the alarm condition and it waits to receive the STOP signal. Passing in STOP and



returning in START the system resumes from the procedure of acquisition of the limit switches. (see chapter: procedure of acquisition of the limit switches).

17.3 Sleep Mode e Standby Motor

When the telescopic linear actuator with START/STOP input in STOP condition is switched on, the Controller immediately enters the inactivity condition called **Sleep Mode and Standby Motor** reducing the absorption from the power supply. This condition of inactivity and reduction of energy absorption also happens every time you switch from the condition of START to the condition of STOP. After the STOP, the condition of Sleep Mode and Standby Motor does not occur immediately, but after a timeout of 5 seconds.

17.4 Security and Alarms

After powering the telescopic actuator with a DC voltage between 10 VDC and 28 VDC, this becomes operational immediately if there are no alarm conditions.

The DC Drive Controller immediately switches to the safety and failure state when one of the following conditions occurs:

- 1) INVALID_START → Alarm-1, invalid start (Invalid START request fault)

This alarm is generated when the DC Drive Controller is switched on if the START/STOP input is in the START condition. By bringing the input back into the STOP condition the alarm is immediately resolved (**restorable**) and the DC Drive Controller is ready for normal operation. This safety is intended to stop any accidental and dangerous departures as required by safety regulations.

- 2) UNDERVOLTAGE → Alarm-2, low supply voltage (Undervoltage fault)

This alarm is generated when the DC Drive Controller is switched on or during normal operation if the power supply voltage should fall below the minimum threshold set by default, **10 VDC** for 12V and **20 VDC** for 24V setting.

This alarm is not restorable, you need to turn off, resolve the cause of the failure and turn on the device.

- 3) OVERVOLTAGE → Alarm-3, high supply voltage (Overvoltage fault)

This alarm is generated when the DC Drive Controller is switched on or during normal operation if the power supply voltage, should rise above the maximum threshold set by default, **17 VDC** for setting to



12V and **28 VDC** for setting to 24V.

This alarm is not restorable, you need to turn off, resolve the cause of the failure and turn on the device.

4) OVERCURRENT → Alarm-4, overcurrent motor (Overcurrent fault)

This alarm is generated during normal operation of the DC Drive Controller if the current of the Motor exceeds the value of the "**Motor current at maximum output power**".

The intervention of this alarm is not immediate to the overcoming of the **current Motor to the maximum Power of output**, but depends on a specific algorithm called **over-current to inverse time** (inverse time overcurrent). The inverse-time algorithm aims to protect the electric motor from excessive exploitation above the nominal characteristics. This algorithm intervenes when the **active current** of the Motor exceeds the **current Motor at the maximum output power** and remains in the range between this current and the **stalling current of the Motor**. Both the **motor current at maximum output power** and the **stall current** are derived from the characteristic curves of the Motor in use, while the alarm intervention time is weighted in a maximum time interval between 5 and 10 seconds. The higher the current absorbed by the motor above the **motor current at the maximum output power** and the shorter the safety intervention time. It should also be specified that for **active current** values of the motor higher than the **stalling current**, for a time greater than **500 ms**, the intervention is immediate. This alarm is not recoverable, you need to turn off, resolve the cause of the failure and turn the device back on. (see paragraph: Reverse time surge)

5) POWER_DRIVER → Alarm-5, anomaly in the DC Motor Control Power Circuit (POWER DRIVER fault)

This alarm is generated during normal operation of the DC Drive Controller if the following fault conditions occur:

- If a **short circuit** condition of the electric motor is detected
- If there is an **over temperature** condition of the Power Stage

This alarm is not restorable, you need to turn off, resolve the cause of the failure and turn on the device.

Note: All non-recoverable alarms, when the device is switched on, are restored only if the fault condition is resolved.



18 Change of motor speed

The motor speed can be modified only in the START condition and in the absence of alarms. To change the speed, use the Speed input as follows:

If it switches 1-0-1 with long zero logical state duration, or $> 0,25$ seconds (250 mS), the motor rotation speed increases with a 10% step from 0 to 100 %.

if it switches 1-0-1 with short duration of the zero logical state, that is 0,2 seconds (200 mS), the motor rotation speed decreases with a 10% step from 100 to 0 %.

Note: On power-on, the system remembers the last set speed before power-off and keeps it until the next change.

19 Virtual limit switch

The telescopic actuator makes use of virtual limit switches to establish the stop point of the motor in both directions of rotation. With this device it is possible to exclude the presence of electromechanical limit switches or the most expensive proximity sensors. The virtual limit switch is simply a numeric value stored in the memory of the microcontroller and interpreted by the latter as a stop value in both directions of rotation of the DC Motor. There are two types of virtual limit switch: reverse or CCW and forward or CW. The reverse limit switch is considered to be the **first limit switch**, while the forward limit switch is considered to be the **second limit switch**.

Both virtual limit switches are set using the limit switches acquisition procedure. Between the first limit switch and the second limit switch there are 64500 encoder pulses. The first virtual limit switch is always assumed to have the value of 500 encoder pulses, while the second virtual limit switch can have a value between 500 pulses and 65000 encoder pulses. The exploitation of the 64500 encoder pulses available, in terms of mm paths, depends on the hardware of the controlled system, for example depends on the transmission ratio, the presence of a screw with a certain pitch, the number of principles of the screw, by encoder pulses per turn etc...

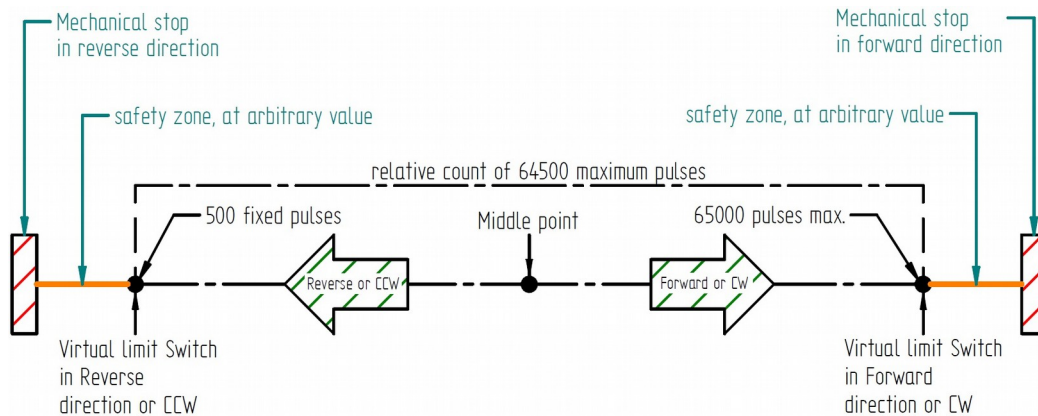

The **average point** of the route is exactly at the half of the total route determined by the limit switches. The Microcontroller calculates this point with an accuracy of ± 1 encoder pulse. During the process of acquiring virtual limit switches, a **safety zone** should be maintained outside the limit switches to avoid collision with the **mechanical stops** of the controlled mechanism. Below we see some application examples in which are listed the fundamental aspects to determine, but not only, the maximum stroke of a telescopic linear actuator system.

Telescopic actuator LATT with 1:12 transmission ratio		
Maximum actuator stroke	4031.250	[mm]
Pulses * mm	16	
Resolution	0.063	[mm]

Telescopic actuator LATT with 1:27 transmission ratio		
Maximum actuator stroke	1791.667	[mm]
Pulses * mm	36	
Resolution	0.028	[mm]

**Telescopic actuator LATT with 1:48 transmission ratio**

Maximum actuator stroke	1007.813	[mm]
Pulses * mm	64	
Resolution	0.016	[mm]

20 Procedure for acquisition of virtual limit switches

The programming of the limit switches requires the execution of a procedure consisting of 5 steps :

Step 1 : In the STOP condition and in the absence of alarms, switch the Speed input to Set Speed ON and keep it switched for at least **5 seconds**, until the OC-OUTPUT output switches 1-0-1-0... etc. with alternation of **0,1 seconds** to signal the condition of acquisition of the limit switches.

Step 2 : Switch the START/STOP input to START. Select the direction of travel with FWD/REV input, the first capture point (**first limit switch**) must be in the rearward direction (REVERSE or CCW). Switch the Speed input to select the rotation speed of the DC Motor or linear actuator. Initially the speed will be zero. If the Speed input switches 1-0-1 with a long duration **> 0.25 sec.** of the zero logical state, the motor rotation speed increases with a 10% step from 0 to 100%. While if Switch 1-0-1 with short duration **< 0.2 sec.** of the zero logical state, the motor speed decreases with 10% pitch from 100 to 0%.

Step 3 : Once achieved the desired position of the **first limit switch**, switch the START/STOP input to STOP to stop the Motor in position. Switch the Speed input to Set Speed ON and keep it switched for at least **2 seconds**. The system acquires the first position of limit switch, signaling the condition by switching the OC-OUTPUT output to 0 for a time of **1.5 seconds**.

Step 4 : Reverse the direction of travel with the input FWD/REV, the second point of acquisition (**second limit switch**) this time will be in the forward direction (FORWARD or CW). Switch the START/STOP input to START, and switch the Speed input to change the speed of movement if necessary, as it remembers the last speed of movement performed.

Step 5 : Once the desired position of the second limit switch is reached, switch the START/STOP input to STOP. Switch the Speed input to Set Speed ON and keep it switched for at least **2 seconds**. The system acquires the second position of limit switch, signalling the condition by switching the OC-OUTPUT output to 0 for a time of **1.5 seconds**



At the end of the acquisition of the second and last position of limit switch, if it happened correctly, the system exits autonomously from the procedure of acquisition of the limit switch and is immediately operating.

Note: during the acquisition phase of the second limit switch the number of motor revolutions or linear displacement in mm paths, have a limit value that cannot be exceeded. Once this limit value is reached, the system stops preventing the continuation.

Maximum motor revolutions allowed = 32250 rpm

Transmission ratio 1:12, maximum linear displacement = 4031 mm

Transmission ratio 1:27, maximum linear displacement = 1791 mm

Transmission ratio 1:48, maximum linear displacement = 1007 mm

20.1 Acquisition of virtual limit switches via DAC console

In order to facilitate the acquisition of the virtual limit switches of the telescopic linear actuator equipped with DC Drive Controller MINI-SA, a console called DAC-MINI-SA has been designed. DAC stands for the **device adjustment console**, specifically dedicated to the control of the MINI-SA model. This console is realized in two versions one to 12 VDC and the other to 24 VDC. The use and connections of the console are very simple. In fact, it is equipped with two unipolar switches for the START/STOP and FORWARD/REVERSE commands, a button for the Speed command and two signalling LEDs. The red LED is the indicator of the alarm or signaling status of the operating state during the acquisition procedure of the virtual limit switches or during the normal operation, while the green LED has the only function to signal the presence of the power supply at 12 or 24 VDC.



On the front side of the console there are two connectors, one of the power supply to 12 or 24 VDC, 5 A and the other for connecting the wiring of the telescopic linear actuator.



20.1.1 Power connector 12/24 VDC, 5A

The power connector has the following electrical and mechanical characteristics:

- maximum supply voltage 30 VDC
- maximum current 5 A
- inner diameter of the jack 2,5 mm
- external diameter of the jack 5,5 mm
- positive polarity on the internal terminal

20.1.2 Identification plate on the back of Console 12 and 24 VDC

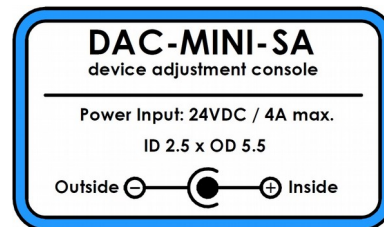
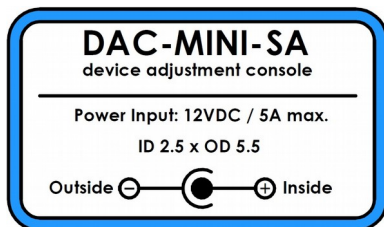



20.1.3 Connector for LATT connection cable

The connection connector to the ALVTT actuator console is a 6-way JST 2.5 mm pitch.

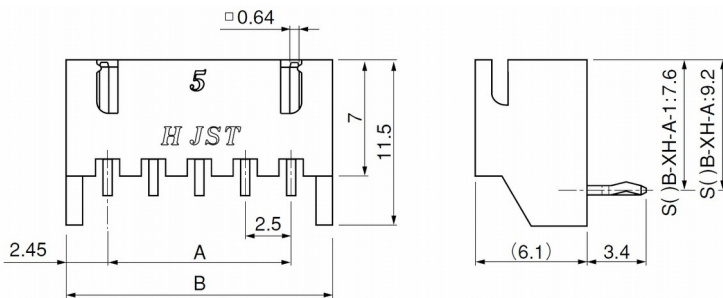

Connector, JST, cod: S6B-XH-A
Terminal, JST, cod: SXH-001T-P0.6

20.1.4 Console operating procedure with LATT and M12 cable gland

The operating procedure if the telescopic actuator with cable gland M12 is used, involves the disconnection of the shielded cable of the LATT connected to the electric system of the equipment and connect it directly to the console to perform, temporarily, programming the virtual limit switches. The power supply should be provided via an external Desktop type power supply. At the end of the procedure reconnect the LATT as previously linked.



20.2 Warnings on the positioning of limit switches

During the procedure of acquisition of the limit switches two fundamental aspects are to be considered: the mechanical stop and the safety zone. Since the choice of the positioning of the virtual limit switches in CW forward direction and CCW backward direction is entirely arbitrary, it is good to locate these positions at a safe distance from the mechanical stop, to ensure a minimum adjustment space on the limit switch and to contain any over-elongations made by the Controller before stopping on the limit switch. Even if these spaces, required by the regulator at the limit switches, have very small values it is recommended not to get too close to the mechanical stop, but leave a safety zone of at least **2 mm**. If during the procedure of acquisition of the limit switches you should reach the mechanical stop and try to



continue further, the DC Drive Controller activates the alarm of overcurrent with immediate stop of the rotation of the DC Motor. If this occurs, the system shall be switched off and on again and the procedure for acquiring the limit switches repeated.

20.2.1 Mechanical stop

The mechanical stop is the most extreme point of the stroke of a mechanism in which all the elements that make up the transmission chain of the motion are tightened against each other preventing the sliding and/or rotation in the direction of mechanical compression. This condition, if reached, is very dangerous and unhealthy for the mechanism, could even cause its rupture.

20.2.2 Safety Zone

The safety zone is the operating space during the adjustments on the limit switch to contain any over-elongations made by the Controller before stopping on the limit switch, even in the worst working conditions.

20.3 Arbitrary positioning of virtual limit switches

Some examples of placement of virtual limit switches:

20.3.1 Full-stroke positioning

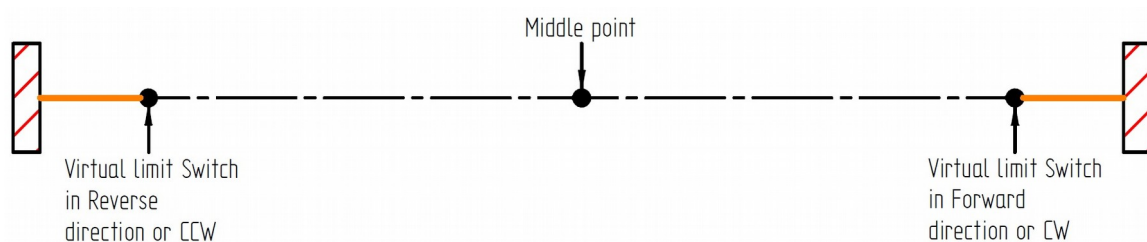



20.3.2 Positioning in the middle

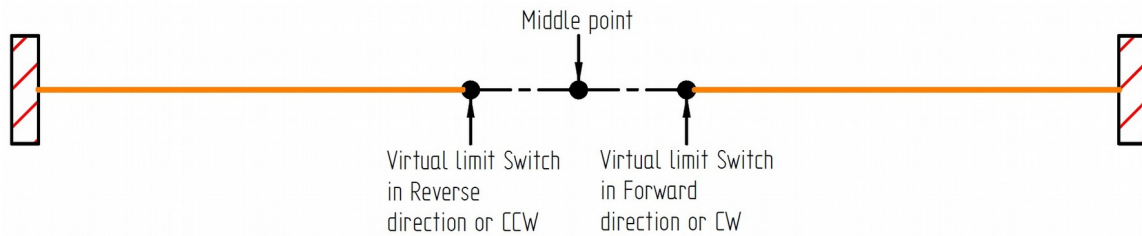

20.3.3 Positioning close to the reverse end or CCW

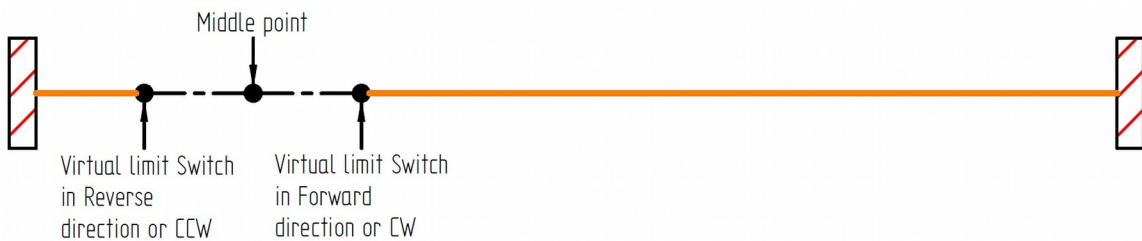

20.3.4 Positioning close to the forward end or CW



Note: the position of the limit switches and the distance from the mechanical stops, indicated by the examples, are completely random and may not even be of any practical use, but have been highlighted only for example because they can be realized with this system.



21 Speed and Position Control

The electric motor control system uses the Hall sensor encoder to get the rotation speed and count the position. Both the **speed** and the **position** are kept constant at the value of setpoint by means of a PID-Feedforward regulator specifically designed for this type of drive, especially dedicated to the control of linear trapezoidal screw actuators. A fundamental characteristic of linear motion is to maintain the required flow rate at constant value, regardless of load variations, within the actuator limits.

Some examples of characteristic speed and position regulator data

operating condition:

- Encoder 2 PPR
- Maximum motor speed DC **14800 RPM**
- rate of approach to reference position **1480 RPM** and acc ramps. /dec. active

values expressed in pulses encoder:

- Maximum overelongation (windup) in worst condition: **13 pulses**
- Maximum deviation around the equilibrium point during adjustment: **± 3 pulses**

values for a generic linear motion application:

1) Application with **1:12** transmission ratio

Maximum over-elongation (windup): **0,8 mm** (coming full stroke on FWD or REV limit switches)
Maximum deviation: **± 0,19 mm** (on limit switch, reference FWD or REV)

2) Application with **1:27** transmission ratio

Maximum over-elongation (windup): **0,4 mm** (coming full stroke on FWD or REV limit switches)
Maximum deviation: **± 0,09 mm** (on limit switch, reference FWD or REV)

3) Application with **1:48** transmission ratio

Maximum over-elongation (windup): **0,2 mm** (coming full stroke on FWD or REV limit switches)
Maximum deviation: **± 0,05 mm** (on limit switch, reference FWD or REV)

Speed adjustment with idle DC motor:

- **± 0.1%** speed error, e.g.: 2000 RPM **± 2 RPM**



22 Acceleration and Deceleration

The run time of the acceleration and deceleration ramps shall always be set to a value referring to the maximum unladen speed, that is to say, loadless, to ensure that the acceleration and deceleration take place in a reasonable space. The duration of the ramps is expressed in mS. The acceleration and deceleration ramps are of the **trapezoidal type** and vary in a linear way from the **first speed** to the **second speed** and vice versa (**trapezoidal motion profile**). If the start takes place with the stopped motor, the first speed is of motor stopped, while the second speed is the current speed or last speed performed. If a change of direction occurs, of the rotation of the DC Motor, during the execution of a ramp, the first speed is the speed of the Motor at that precise moment, while the second speed can be the current speed of the Motor if we are in acceleration or the zero speed, of Motor stopped, if we are in deceleration. The **trapezoidal pendular motion**, it can be obtained by intervening only on the change direction.

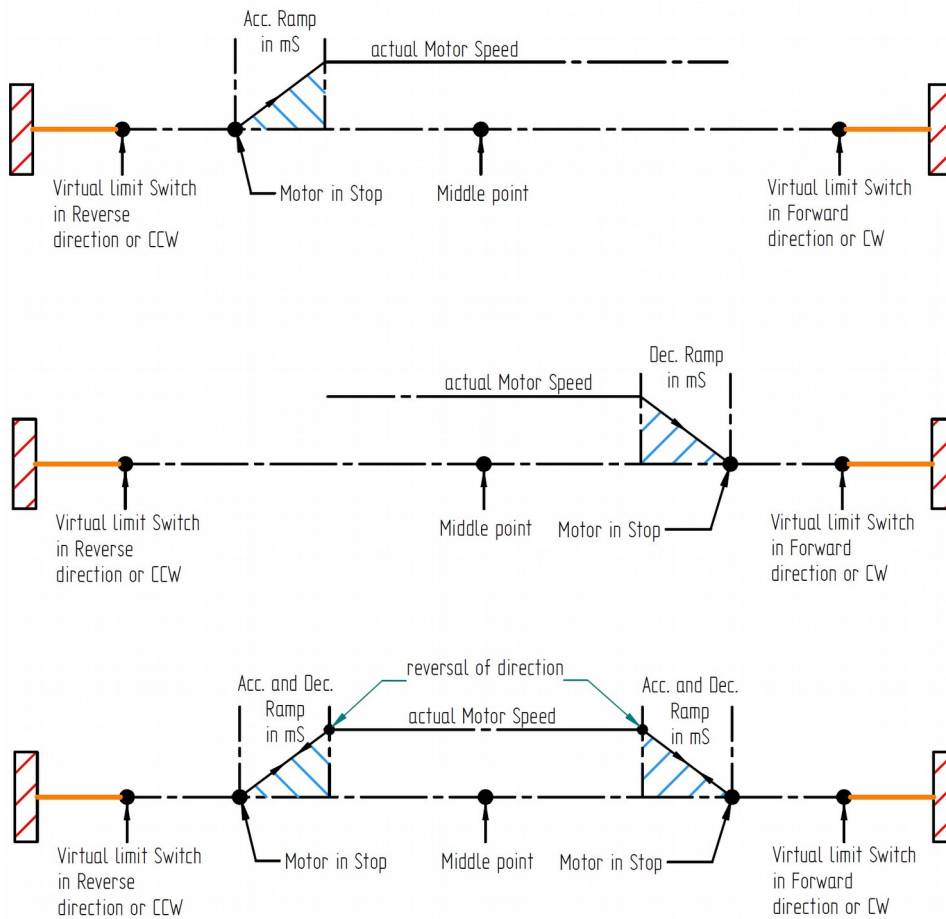



23 Automatic deceleration before the stop

The automatic deceleration before the limit switch is always active and set to a value equal to 10% of the maximum rotation speed of the DC Motor. This is also the speed of adjusting the position on the Forward Limit Switch (CW) and Reverse Limit Switch (CCW).

The insertion point before the Stop of the automatic deceleration, in mm or encoder pulses, is set to a value to ensure the achievement of the position reference (setpoint), to 10% of the maximum speed of rotation of the DC Motor, in a reasonably short time. This parameter is called **Deceleration space before the Forward/Reverse limit switch**, while the speed parameter is called **Minimum speed in the automatic deceleration zone**.

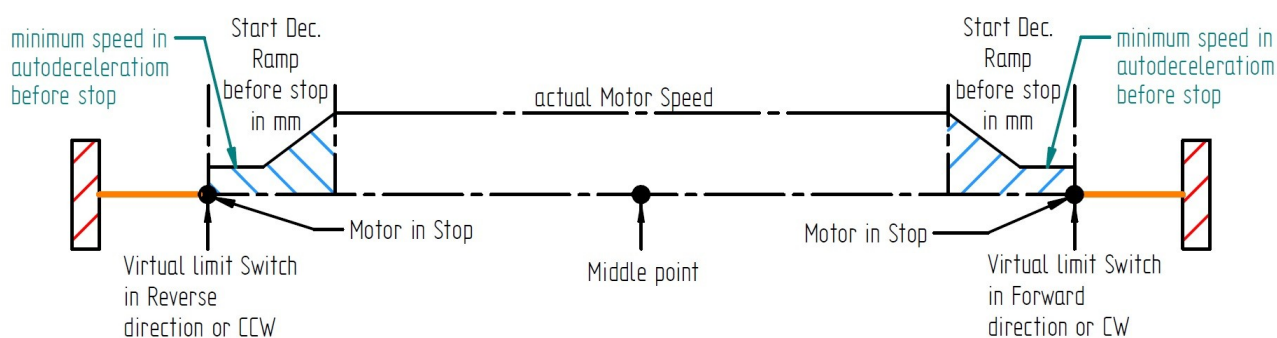

If both parameters are reasonably chosen, they are sufficient to guarantee a good performance, reducing mechanical stresses to the advantage of the useful life of the controlled mechanism.

24 Dynamic Acceleration and Deceleration

The dynamic acceleration and deceleration is always active in order to guarantee times and spaces of deceleration and acceleration proportional to the speed of rotation of the DC Motor, therefore of the system where applied.

In the case of linear actuators with trapezoidal screw, this characteristic of acceleration and dynamic deceleration, favors the optimization of the forward/backward displacement, reducing waiting times during full-stroke reversals and during slowdowns and accelerations on limit switches, especially at low speeds.

The algorithm of acceleration and dynamic deceleration, changes both the time of acceleration and deceleration and the space of the dynamic deceleration before the Stop, as a function of the speed of rotation of the DC motor. The lower the speed, the shorter the acceleration and deceleration times and



space. The higher the speed, the higher the acceleration and deceleration times and space up to the maximum limit set in the relative parameter. This algorithm excludes ramps when the rotational speed of the DC Motor is equal to or less than 10% of the maximum speed.

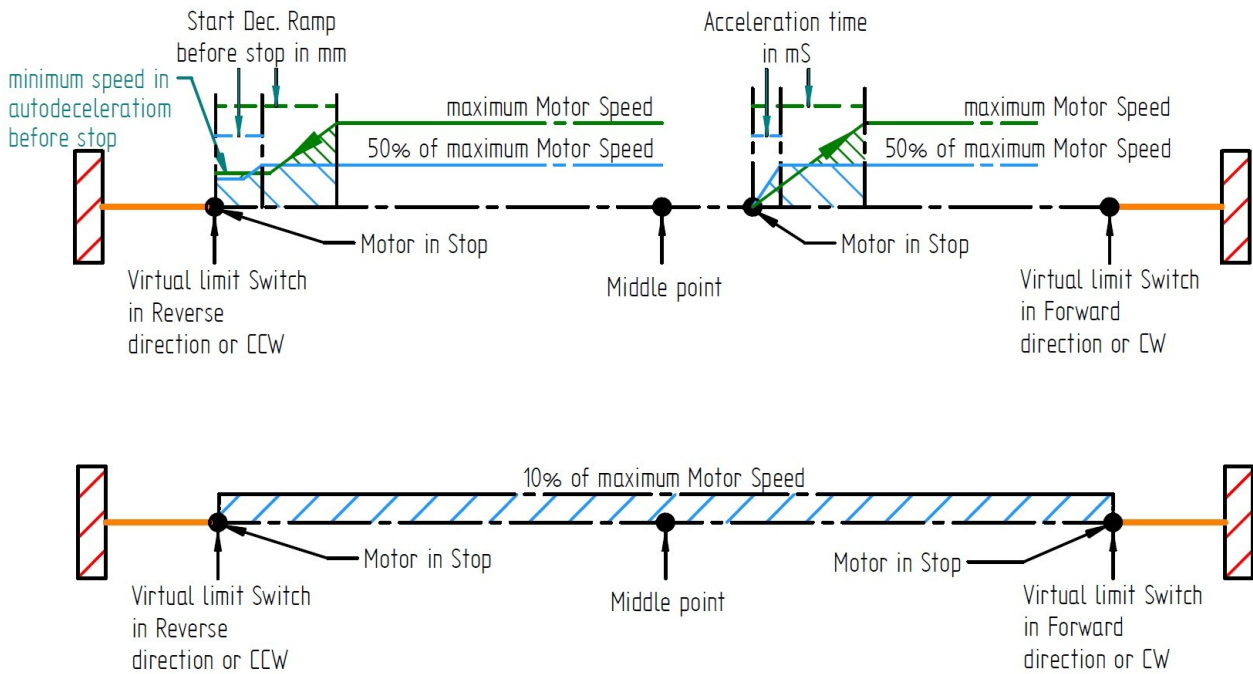



25 Switching from START to STOP to START

From the START, passing into the STOP operating condition, the rotation of the DC motor is stopped in a very short, almost instantaneous time, excluding the deceleration ramp. Switching again in START, the rotation of the DC Motor resumes in the direction of rotation selected, executing the acceleration ramp.

In the **first example** it is possible to see that the departure takes place with the motor stopped. By selecting the START command the DC Motor starts the acceleration ramp in the forward direction or CW, at the end of the ramp continues at the current speed. By activating the STOP condition the DC Motor stops instantly. Selecting the START command again and remaining in the same forward direction or CW, the DC Motor repeats the acceleration ramp and after finishing it continues at the current speed.

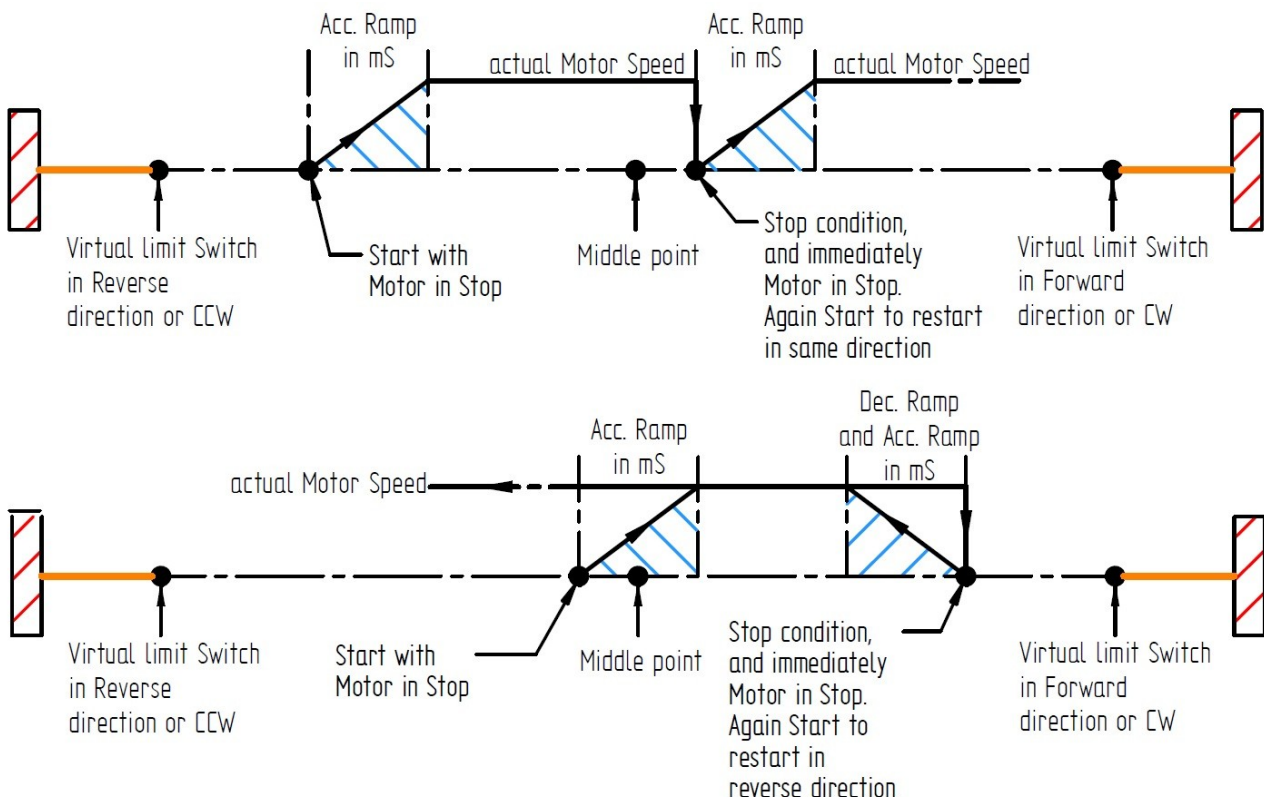

In the **second example** it is possible to see that the start takes place with the motor stopped. By selecting the START command the DC Motor starts the acceleration ramp in the forward direction or CW, at the end of the ramp continues at the current speed. By activating the STOP condition the DC Motor stops instantly. Selecting the START command again, but in the opposite direction, reverse



direction or CCW, the DC Motor repeats the acceleration ramp and after finishing it continues at the current speed in the opposite direction.

26 Last position reached

This control system for telescopic linear actuators has an indispensable feature to work with the virtual limit switches, that is, to remember at each ignition the exact position reached the instant before shutdown. In fact, the microcontroller stores the position in two very precise circumstances. The **first condition** concerns the Motor in the STOP condition. The microcontroller stores the position after **5 seconds** from the STOP, but only if the position has changed or better to say different from the previous one. The **second circumstance** concerns the shutdown of the control system of the telescopic linear actuator. The microcontroller stores the position during the shutdown of the drive even if a rotation of the motor is in progress. In the latter case the Motor is first stopped quickly and then the position is stored with the Motor in STOP.

26.1 Endurance

This continuous storage of the position inside an EEPROM memory introduces a very important parameter that establishes the life of the product: **endurance** expressed in writing cycles. The number of maximum write cycles depends on only one external variable, that is the temperature. The higher the temperature at which the DC Drive Controller is located, the lower the write cycles that can be performed. If the average working temperature of the device remains in the around **25 ° C** we can declare a lifespan equal to at least **5.000.000 cycles of writing of the position** reached. In this regard, the error of confusing the number of writing cycles with the number of placements should not be made, since the writing of the position occurs only in the circumstances described above. Therefore, the number of placements can tend to very high values and even exceed the average duration of the mechanism.

It should also be specified that it is impossible to establish with absolute certainty how many cycles of writing of the position will be carried out until the end of the life, As the temperature depends a lot on the working conditions and can have a very variable behavior over time and depending on other external factors as well as the application modes. In other words, we can assert that if the temperature will be, in more occasions, less than 25 C, the greater will be the quantity of the cycles of writing of the position reached, realizable.

26.2 Irreversibility of the mechanism

It should be specified that this system is ideal when applied to irreversible mechanisms, in which the rotation of the mechanism does not occur accidentally or after system shutdown, but by means of the microcontroller, such as for example in **linear trapezoidal screw actuators**.